



Features

- Superb audio and music reproduction performance
- High-strength ABS material
- Flush-mounting system for fast and easy installation
- Perfectly integrated into all indoor places IP66 Level
- Comply with CE standards

Specification

Electrical	
Max Power	9W
Rated Power	6W
Power Tap	6W/3W
Sensitivity(1m/1W)	88dB
S.P.L(1m/6W)	95dB
Frequency Response	195Hz - 20kHz
Input Voltage	100V
Rated Impedance	8Ω
Connection	Three core cable
Mechanical	
Dimensions	Φ140 x 80mm
Hole For Mounting	Φ125mm
Panel	ABS
Net cover	White iron mesh
Color	White(RAL9016)
Speaker size	4"
Product Weight	0.825kg
Quantity of inner box	1PC
Inner Box Dimension	16 x 14.5 x 12cm
Gross Weight/Qty	16Kg/16PCS
Outer Box Dimension	62 x 35 x 28cm
Environmental	
Operating Temperature	-25°C to +55°C
Storage Temperature	-40°C to +70°C
Relative Humidity	≤95%

Three Views

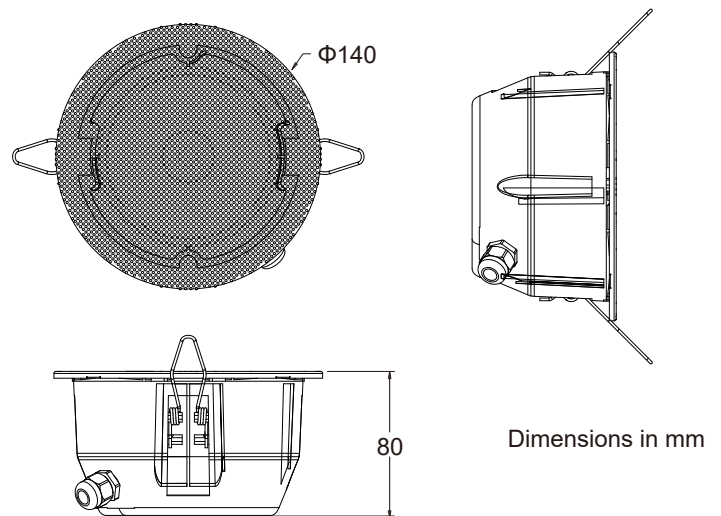

Circuit Diagram

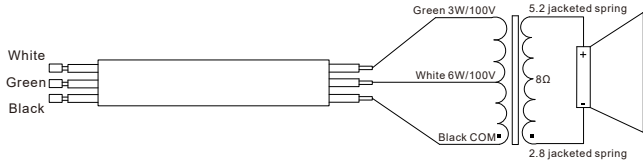

Installation Instruction

1. Make a 125 mm diameter mounting hole in the ceiling.

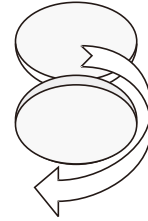

2. Wiring

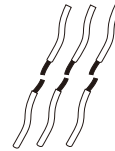

Frequency Response Diagram

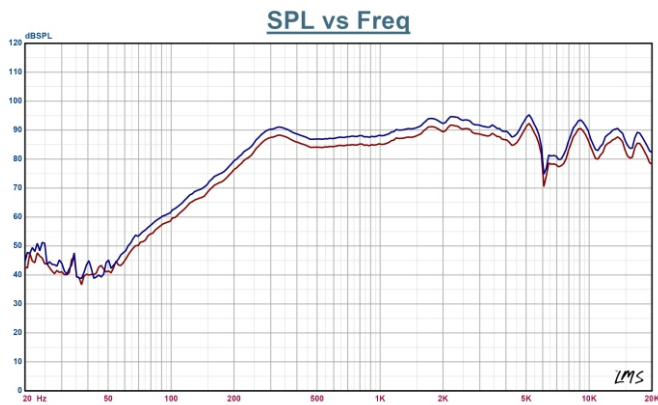

3. Pull the speaker clip upward and put it into the ceiling hole.

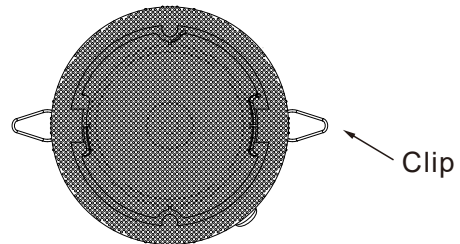

Impedance Diagram

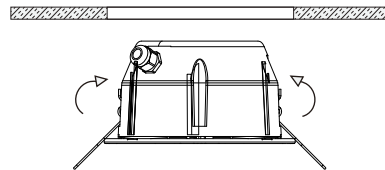
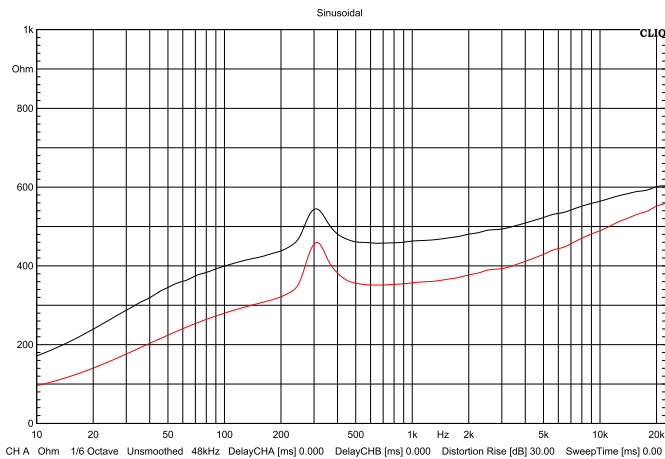

4. Press the speaker into the ceiling in place, and the clip will automatically recover and compress the speaker.

